

RevNo	Revision note	Date	Signature	Checked

**NOTES**

**1. MATERIALS:**

HOUSING-NYLON 46 30%GF UL94V-0.

CONTACT-PHOSPHOR BRONZE, C5191R-H T=0.6mm.

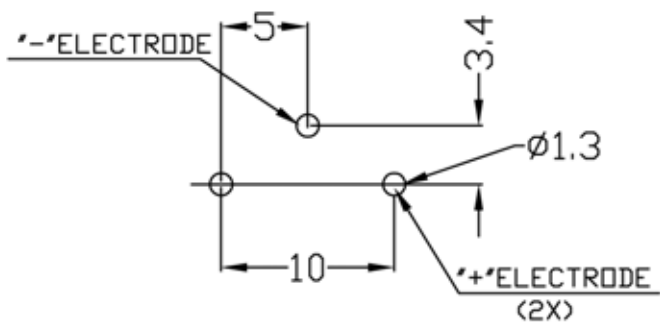
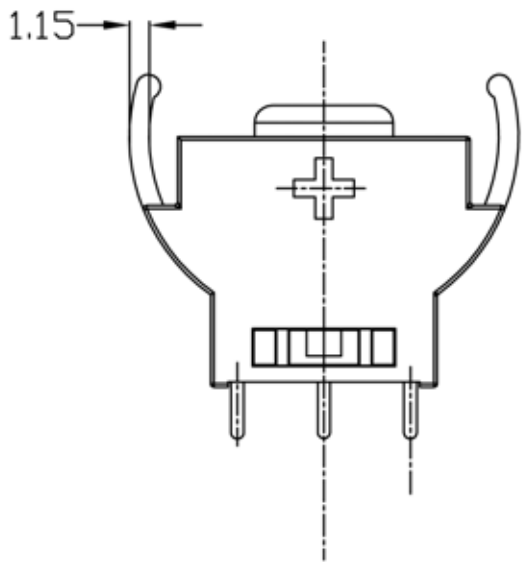
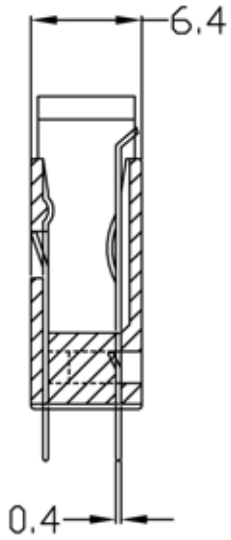
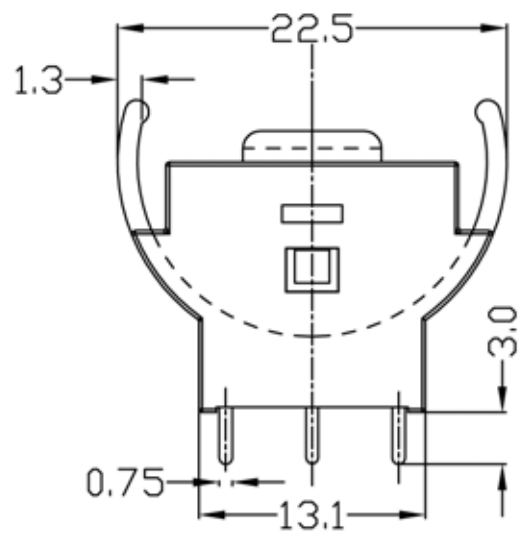

握柄	匣	??規
	50	±0.05
50	120	±0.10
120	250	±0.15
250	400	±0.30
400	650	±0.50

**BATTER HOLDER:**  
**GS074A-021X**

CUSTOMER:

PART NO.:                      MATERIAL:

DWG NO.:                        QTY:

MODEL NO.:                      FINISH:

DRAWN BY:                      DATE:

CHECKED BY:                    DATE:

APPROVED BY:                    DATE: 2003/04/30

SCALE: 1 : 1                      SHEET NO.                      NO. OF SHEET